

★ BRING US TO YOUR FACILITY ★

Or Check Our Website For Classes Near You

ONE DAY OF INTENSIVE TRAINING

# PROGRAMMABLE LOGIC CONTROLLERS

using

DirectSOFT6™ Software and  
Automation Direct DL105™ PLCs

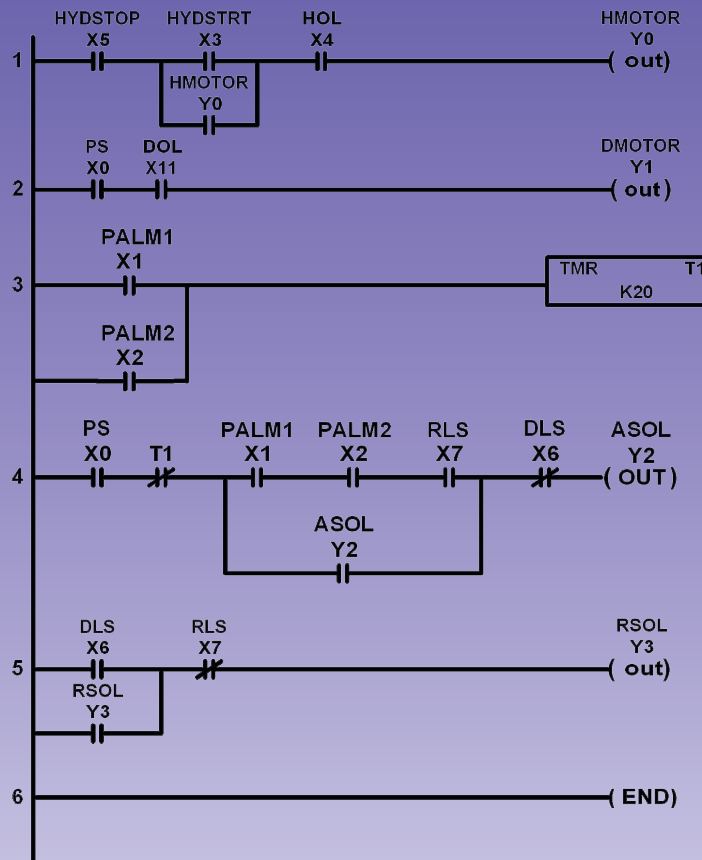

EIGHT  
HANDS  
ON  
LABS

TRAINING  
1996  
SINCE

No PREVIOUS  
PLC  
EXPERIENCE  
NECESSARY

*"Took away the intimidation factor from PLCs and ladder logic. Made it seem easy and straight forward as it actually is. Makes you realize that there is no magic involved, it is just a machine."*

*Roger Stephens - Monsanto*



**Impact**  
Training Services, Inc.

Training that "WORKS"™

(502) 252-9128 or [www.impactu.com](http://www.impactu.com)

**"EXCELLENT BEGINNING COURSE. I'M LOOKING FORWARD TO FIELD EXPERIENCE AND ADDITIONAL TRAINING CLASSES IN THE FUTURE."**

**BRUCE AKINS - CSX TRANSPORTATION**

# COURSE OUTLINE

## EQUIPMENT USED

**Automation Direct DL105™ PLCs**  
**DirectSOFT6™ Programming Software**  
**Laptop Computers**  
**Voltmeters**  
**Text and Lab Manual**

## GENERAL TOPICS

### PLC Sections

Power Supply  
Central Processing Unit (CPU)  
Memory  
Data  
Program  
Input Section / Output Section

### Scanning

How Programs Are Executed  
Data Memory Operation

### Input and Output Boards

Types  
Functions  
Termination  
Isolation  
Translation  
Threshold Detection  
Indication

## LADDER LOGIC TOPICS

### AND, OR, NOT

**Logical Continuity**  
**Reading Ladder Logic**  
**Instructions**

Input/Output  
Internal Coils  
Set/Reset  
Timers/Counters

## HANDS-ON LABS

**Using Automation Direct DL105™**  
PLCs and Direct SOFT6™  
Programming Software

## Troubleshooting

CPU Faults  
Power Problems

## Instructions

Input/Output  
Series/Parallel  
Internal Bit (Software Relay)  
Set/Reset (Software Latching Relay)  
Timers  
Counters

## TROUBLESHOOTING TOPICS

### Diagnostics

### Data Memory Monitoring

### Search Commands

### Input Side

Switches  
Wiring  
Testing Input Boards

### Output Side

Loads  
Wiring  
Testing Output Boards

### Central Processing Unit

Visual Indicators  
Faults, How To Clear Them  
Lost Programs

### Power Supply

Visual Indicators  
Checking Voltage Levels  
Checking Fuses

### Using the Ladder Logic to Troubleshoot

Troubleshooting With the Program  
Displaying Rungs  
Searching for Problems

*"The instructor was fantastic. It was well worth my time."*  
**Jeffrey Craig - Caterpillar Inc.**

\* AutomationDirect DL 105™ and DirectSOFT6™ are registered trademarks of AutomationDirect

**BRING ANY OF OUR CLASSES TO YOUR FACILITY**

**(502) 252-9128 or [www.impactu.com](http://www.impactu.com)**